

Inputs 1 to 5

Input 1 Postal Lock. Input 1 connects to the Postal Lock. Activation of this input unlocks the main door and starts the main door timer. Daily usage is limited according to a pre-defined number.

Input 2 Fire Panel. Input 2 connects to the fire alarm panel and receives fire notification. Activation of this input unlocks the main and auxiliary doors.

Input 3 Main Door Sense. Input 3 connects to the door sense switch.

Activation of the Main Door Sense locks the main door and resets the main door open timer.

Inputs 4 and 5 General Purpose. Inputs 4 and 5 are general purpose inputs that, when configured, activate a general purpose output to perform any required function.

Telephone Lines 1 to 5

TX3 supports full ADC and NSL telephone connectivity from a single Telephone Access System panel or from a networked system. A single panel supports up to five ADC and/or NSL telephone lines. Each T/R line is polarity insensitive and can be reversed.

Jumpers

JW1. Leave open. Short only when updating firmware.

JW2. Leave open. Short only when updating firmware.

JW3. Leave open. Not used.

JW4. Leave open. Not used.

JW5. Leave open. Not used.

JW6. Leave open. Not used.

JW7. Leave open. Not used.

JW8. JW8 defines the operating state of the door strike relay as normally open or normally closed. A jumper wire connects to either the normally open (top position for a door strike) or normally closed pin (bottom position for a maglock).

Connections

USB. Computer connection for firmware download and configuration.

P4. TX3-MDM Modem Board connector.

P6. Key pad and front door LCD display.

P7. Guard Phone Board connector.

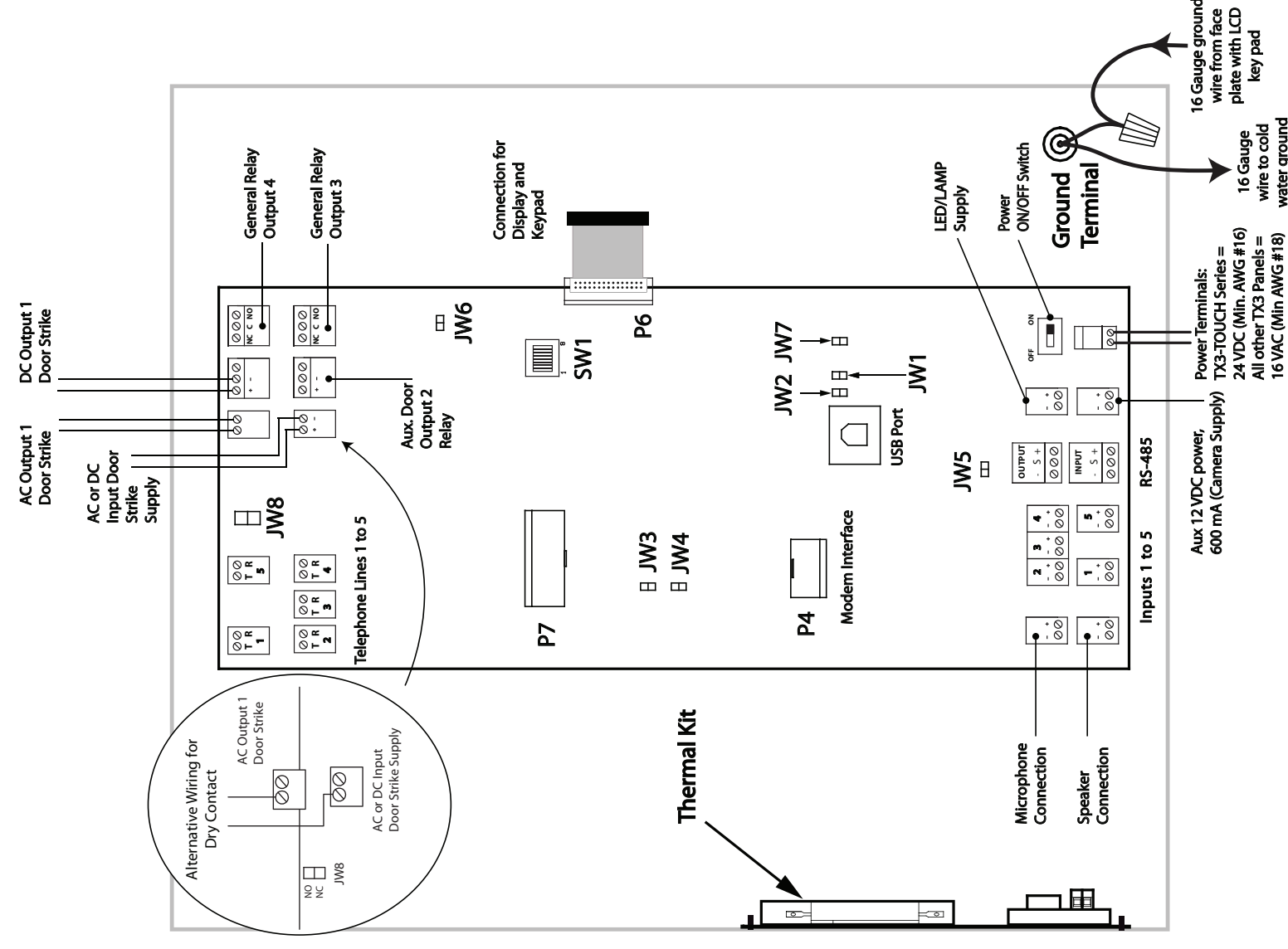

AC or DC Input Door Strike

The power for the door strike is customer supplied and provides AC or DC power for one of the door strike outputs. The controller converts an AC supply to a DC output. The reverse is not true. An AC door strike will not work with a DC power supply. The maximum supply for the AC or DC Input Door Strike is not to exceed:

- 30 Vdc \ 3 amp
- 30 Vac \ 1 amp

AC Output 1 Door Strike

The AC Output Door Strike receives power from the AC Input Door Strike supply. The AC power output remains the same as the power supplied to the AC Input Door Strike.

DC Output 1 Door Strike

The DC Output Door Strike receives power from the AC or DC Input Door Strike supply. When using a DC Input Door Strike supply, the DC power output remains the same as the input.

Outputs 2 to 4

See LT-969 Telephone Access System Installation and Operation Manual.

SW1

SW1 sets the Telephone Access controller network address. Use DIP switches 1 to 6 to set the network address. Keep DIP switches 7 and 8 at the factory set values.

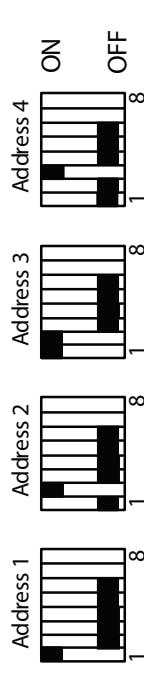

RS-485

The RS-485 connection consists of an input and output terminal. Connect the RS-485 output terminal to the RS-485 input terminal of the next controller. Connect the last controller on the network to the RS-485 input terminal. Refer to LT-969 section 4.2.4 for end of line resistors to be used on the first and last nodes of network. The RS-485 terminal consists of + (positive), - (negative), and S (Shield) connections.

Ground Terminal

The Telephone Access system is equipped with a 16 gauge electrical wire attached to the Ground Terminal in the back box. Do not disconnect this wire. Attach the end of the supplied wire to a suitable grounding wire 16 gauge or thicker. Attach the other end to the cold water ground.

Another ground wire is attached to the face plate, ensure it is connected to the ground terminal in the backbox.

The following figure shows the various controller connections

Wiring requirements

- Install all transformers outside the Lobby Control Unit enclosure.
- Unless specified otherwise, all wiring is a maximum length of 1000 ft. The RS-485 wiring maximum length is 4000 ft.
- All units use the PS-4P transformer for the power supply using 18 gauge wire. The door strike power supply depends on the door strike power requirements.

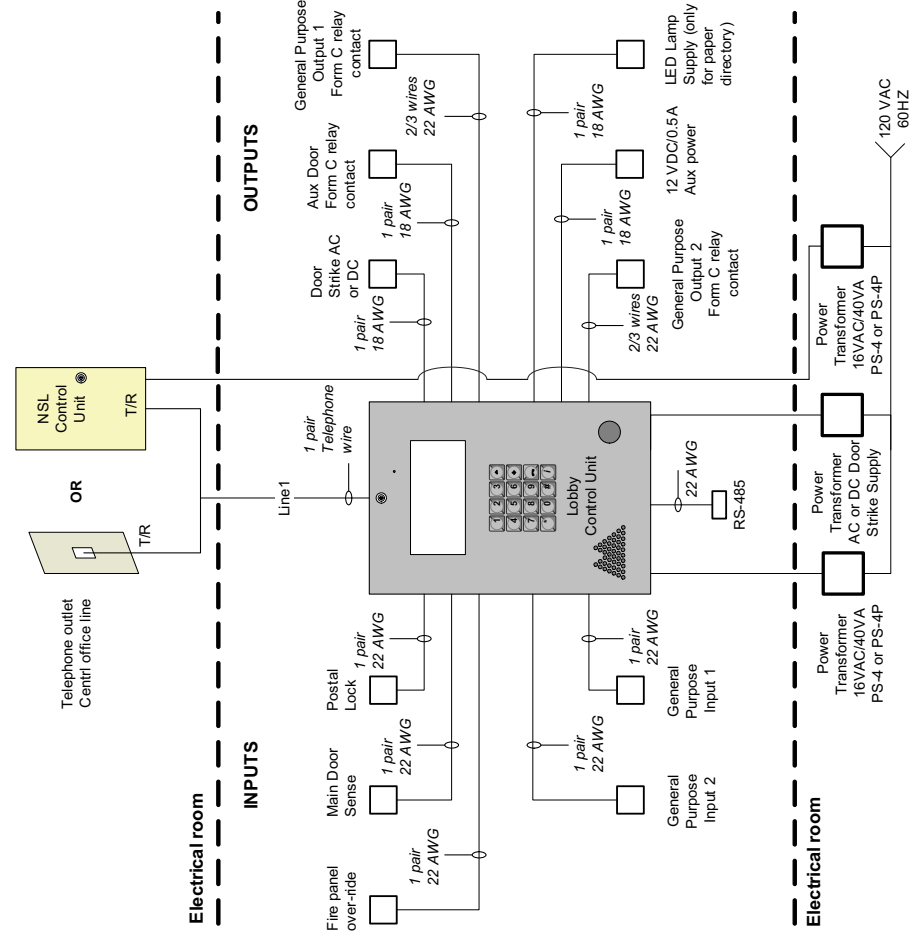

Single Entrance System Wiring

Controller Board Connectors - Bottom

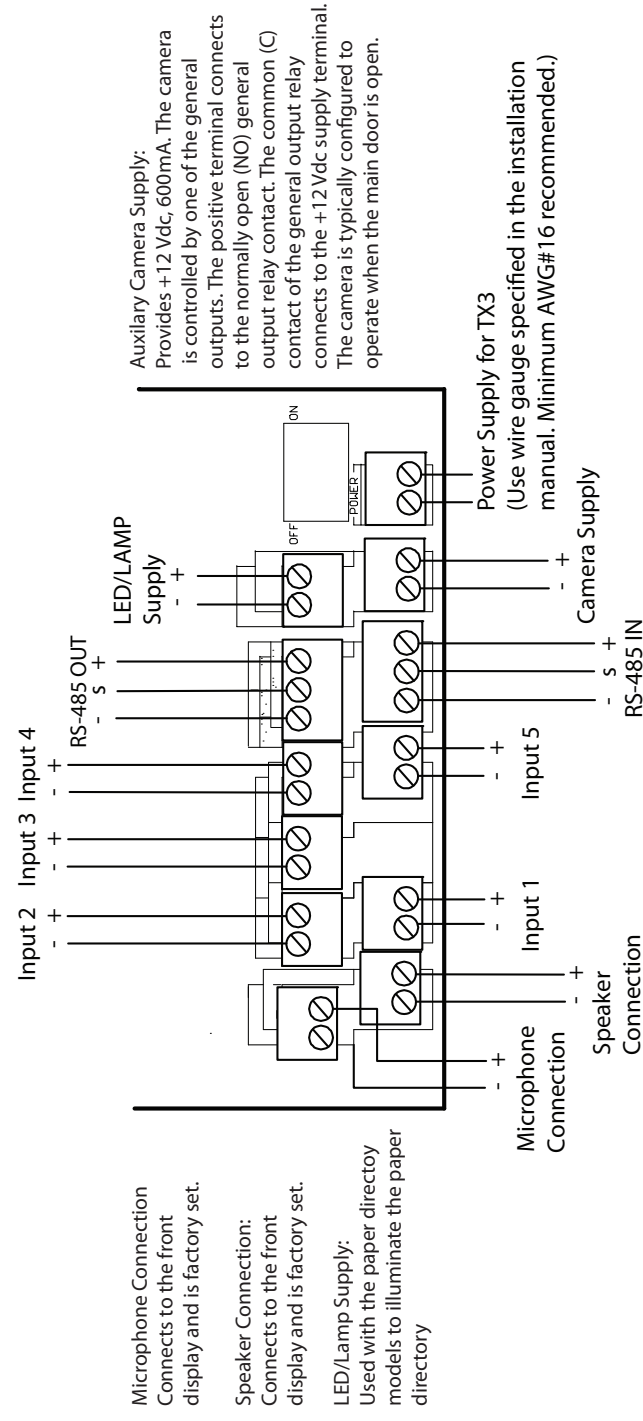

Telephone Access System Quick Reference

IMPORTANT

This document is for reference only and does not replace the existing documentation. For more detailed information refer to the documentation on the CD or Mircom website (www.mircom.com).

Installation Prerequisites

- Verify that the building telephone infrastructure is operational. When wiring an NSL installation it may be necessary to check each resident's line.
- Ensure there is a provision for a ground circuit. The Telephone Access System assembly must be grounded by a qualified electrician. An improperly grounded unit can result in equipment malfunction and void the warranty.
- Use the latest Telephone Access System controller firmware. Mircom periodically updates panel firmware and Configurator Software to add features and correct any minor inconsistencies. For information about the latest firmware or software visit the 'Manuals and Downloads' section of the Mircom website at www.mircom.com.

Basic Wiring

1. Turn the controller power switch to OFF.
2. Connect the telephone line to the Line 1 terminal on the controller board.
3. Connect the AC or DC door strike.
4. Connect door strike supply.
5. Connect the controller supply using 18 gauge wire.
6. Set JW8 as either normally open or normally closed to control the door strike operation.
7. Set SW1 with a unique network address.
8. Turn the controller power switch to ON.

Before Starting the Configuration

Configure the system using the front keypad or the Configurator software using a USB or modem connection. Verify the following:

- Ensure that the controller and all connected devices and components are fully operational.
- Ensure the controller DIP Switches (SW1) are set with a unique network address.
- Ensure the Configurator software is set with the correct controller network address.
- Ensure that your PC is set with the correct date and time.

To Start the Configuration

1. Connect the PC to the controller using the USB port or modem connection.
2. Launch the Configurator and select the correct controller you are connecting to (on the basis of name, panel label, panel model, and network address).
3. Click Connect. Once connected the connection icon appears in the Configurator tool bar.
4. Ensure that the panel is configured with the correct data and time.
5. Configure the Telephone Access system using the instructions in the LT-995 Configuration and Administration Manual.