

MIRCOM

**EP-2000
INSTALLATION
MANUAL**

LT-516
REV 0

TABLE OF CONTENTS

	PAGE
1	BACKBOX HOUSING INSTALLATION..... 2
2	SYSTEM WIRING..... 3
3	HARDWARE..... 3
4	SYSTEM TRANSFORMER..... 4
5	DOOR STATION..... 4
6	REMOTE ROOM STATION..... 5
7	AUXILIARY INPUT..... 5
8	ELECTRIC LOCK..... 5
9	AM & FM ANTENNAS..... 6
10	FINAL SYSTEM HOOK-UP..... 6
11	TROUBLE SHOOTING CHART..... 7

INTRODUCTION

The EP-2000 system is very easy to install. All wiring connections are easily identified on the Terminal Board.

1. BACKBOX INSTALLATION

- A) Locate the master backbox(MB-804), the indoor ring(IB-810) and the Outdoor ring(OB-1000) at convenient locations.
- B) Do Not install in areas of extreme cold or direct heat.
- C) Do not install two stations back to back in the same wall partition as this may cause feedback(see figure 1a)
- D) See figure 1b for outdoor ring (OB-1000) installation.
- E) The Master Backbox requires 9cm(3 5/8inches) depth behind the wall surface and the master protrudes 3cm (1.25 inches) in the front
- F) When installing the master backbox housing underneath kitchen cabinets, make sure to leave a minimum of 12 cm(5 inches) of clearance at the top. This space will be required for final installation (see figure 1c)

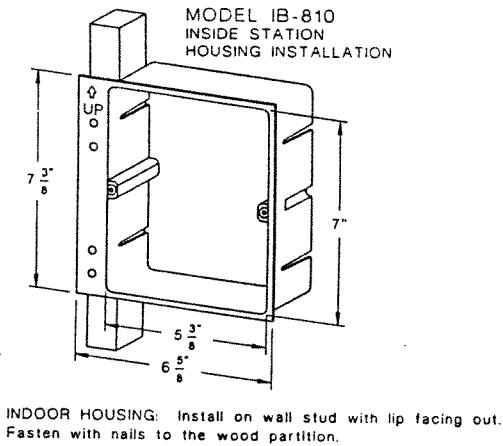

FIGURE 1a

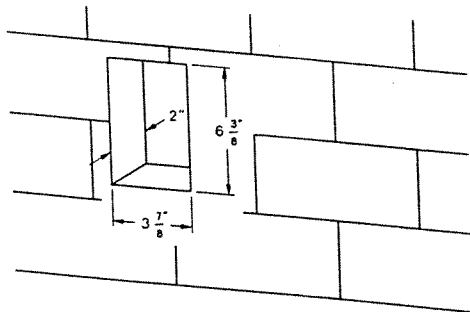

FIGURE 1b

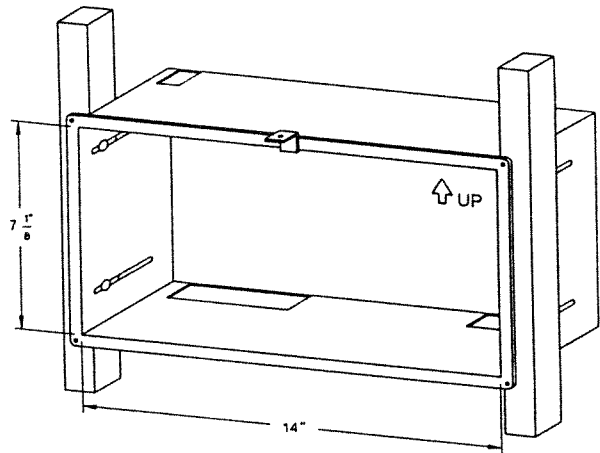

FIGURE 1c

2. SYSTEM WIRING

CAUTION

Do not make any wiring connections with the power on. Damage will occur and warranty will be voided

- A) The EP-2000 system can be wired using non-twisted cable. Four conductors are required per remote station (IS-2000/OS-2010).
- B) The maximum distance from the EP-2000 Master Station to a remote station (IS-2000/OS-2010) is 60 metres (200 feet) when using 22AWG wire
- C) All station wiring(IS-2000) and door station wiring(OS-2010) must be home run back to the master backbox.
- D) Cables must be installed away from power wiring, transformers, fluorescent lights, lighting dimmers and other electrical fixtures. Do Not install wire in same conduit with power wiring

3. HARDWARE INSTALLATION

- A) Install the upper mounting clip to the master backbox with the two #6 self tapping screws provided(See Figure 2a).
- B) Install the hinge mounting screws. Do not fasten them all the way down, the hinge will be fasten by these screws. (see figure 2a).
- C) Mount the intercom terminal board to the right side of the master backbox(MB-804) with four #6 self tapping screws (see figure 2a)

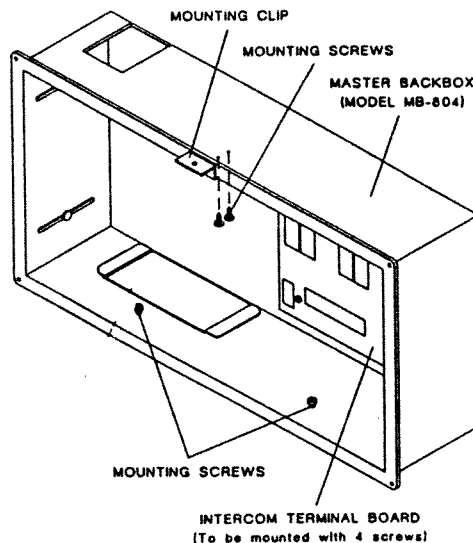

FIGURE 2a

4. SYSTEM TRANSFORMER

- A) The EP-2000 system requires a 16V 75VA transformer for proper operation. It should be installed near a source of 120VAC, the fuse panel is a good location.
- B) Use 3 conductors 18AWG wire from the transformer to the EP-2000 master. If the distance is greater than 15m (50 feet) use 16AWG.
- C) The transformer connections are made at TB3 on the intercom terminal board(see figure 3)
- D) Caution do not apply power to the system at this time

5. DOOR STATION

- A) Three door stations can be connected to the EP-2000 system. Each door station requires its own OS-2010 interface module.
- B) The OS-2010 interface module should be installed within 1m (3 ft) of the door station. If the OB-1000 backbox is used, the OS-2010 can be installed inside of it.
- C) Only one door station per cable and wiring must be home run.
- D) See Figure 3 for wire connections.

NOTE:

Connecting wires "V" and "D" to the following terminals on TB2 determines the type of chime and station number.

Terminal Location	Chime	Station No.
Front Door V & D	3 note	14
Side Door V & D	2 note	15
Back Door V & D	1 note	16

6. REMOTE ROOM STATION -- IS-2000

- A) Twelve IS-2000 remote stations can be connected to the EP-2000. Only one IS-2000 station can be connected per cable. All wiring must be home run (see figure 3).
- B) The terminals on the EP-2000 that wires "V" and "D" from the IS-2000 are connected to determine the station number. For example, when connecting "V" and "D" from IS-2000 to "3V" and "3D" on the EP-2000 terminal board make that Station Number 03. The Plus and GND terminals are common for all stations.

NOTE

Each room station is identical except that by connecting a room station to terminals "2V" and "2D", you program this station to be the master room station. The master room station is typically the master bedroom station. This station is able to override any other room station setting and can not be monitored(See Operating instructions).

7. AUXILIARY INPUT

- A) An Auxiliary music source(tape desk, CD) can be connected to the EP-2000 system. It is recommended that shielded cable be used for this connection. The output level from the Auxiliary Source should be 100mV to 200mV.
- B) The input level can be adjusted with the potentiometer on the intercom terminal board.
- C) The Auxiliary connections are made on TB4.

8. ELECTRIC LOCK

- A) The relay output terminals on TB2 are used to control an optional relay (RL-1000) that can be used to control an electric lock
- B) The electric lock can only be triggered if the door chime push button is pressed. The electric lock will stay energized for approximately 5 seconds.

9. AM & FM ANTENNAS

A) AM Antenna

AM reception is affected by power lines, atmospheric conditions, hills and tall buildings. You can try the following to improve the reception:

- I. The AM antenna is a co-axial type wire. An external wire may be connected to the middle conductor and extended upwards to improve reception
- II. It is important to keep the AM antenna wire away from AC lines, metal parts and all station field wiring.
- III. Connect a wire from building ground to the terminal board(TB3)

B) FM Antenna

An external antenna wire can be connected to the FM wire(white wire fasten around the inner perimeter of the Master Unit) to improve the reception if required.

10. FINAL SYSTEM HOOK-UP

- A) Once all the field wiring is completed, slide the support hinge underneath the 2 mounting screws and fasten tightly.
- B) Plug P1, P2, P3 and P4 from the EP-2000 into the corresponding plugs on the terminal board.
- C) Assemble the master unit to the backbox by installing the top fastening screw.

11. TROUBLE SHOOTING GUIDE

- A) **Nothing Works - No AC Power**
 - Check for 16AC from transformer
 - Check 3AMP fuse on Power Supply

- B) **Keypad Dead on Master - Defective room station, Miswired**
 - Power system down and remove P2 and P3 and check EP-2000 master only
 - Check room station by disconnecting one at a time
 - Check system wiring

- C) **No Door Chime - OS-2010 Module**
 - Check wiring to OS-2010 module
 - Check push-button on outdoor station

- D) **Hum in Speaker - Intercom wiring runs too close to house**
 - AC wiring/interference from household electrical fixtures
 - Keep intercom wire as far as possible from household AC power wiring

- E) **Room Station Not Working - Incorrectly wired/defective room station/terminal board**
 - Check wiring at room station and at master
 - Connect to a different station position on intercom terminal board

- F) **No Door Communication - OS-2010 module/microphone/speaker door station**
 - Check wiring to OS-2010 module
 - Check speaker
 - Check microphone

FIGURE 3

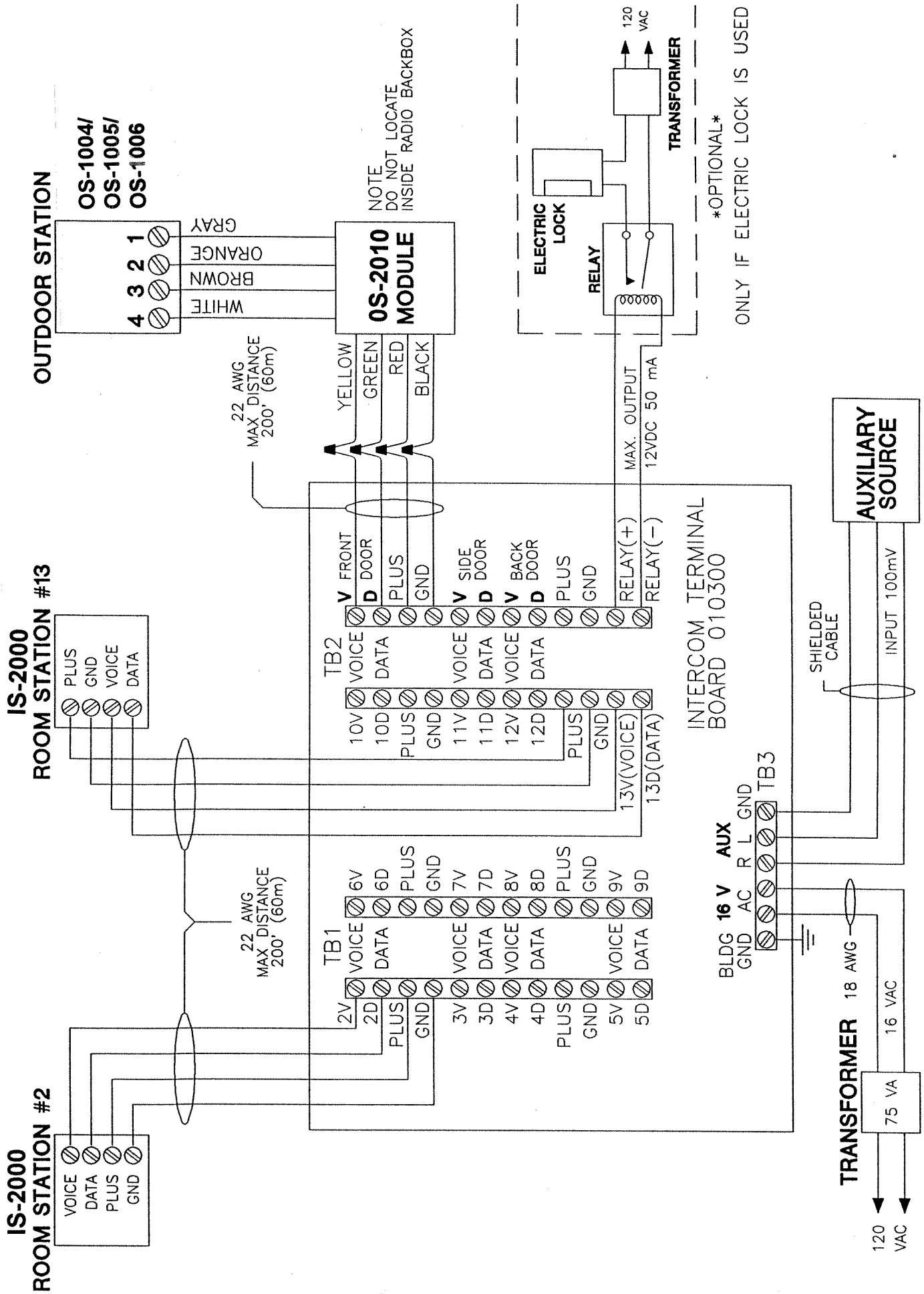

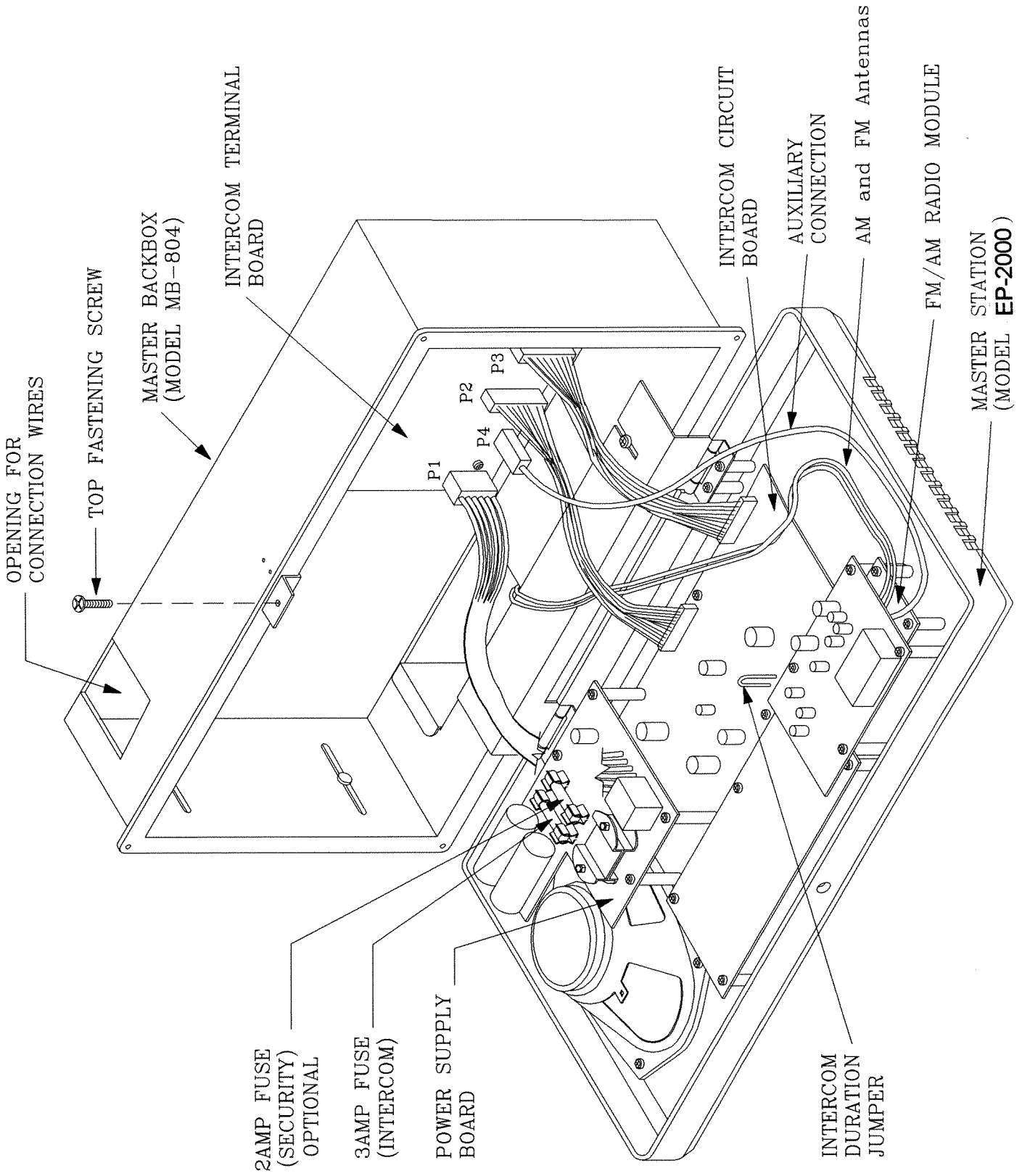

FIGURE 4

WARRANTY

MIRCOM Technologies Ltd., manufactured equipment is guaranteed to be free of defects in material and workmanship for a period of two (2) years from the date of original shipment. MIRCOM will repair or replace, at its option, any equipment which it determines to contain defective material or workmanship. Said equipment must be shipped to MIRCOM prepaid. Return freight will be prepaid by MIRCOM. We shall not be responsible to repair or replace equipment which has been repaired by others, abused, improperly installed, altered or otherwise misused or damaged in any way. Unless previously contracted by MIRCOM, MIRCOM will assume no responsibility for determining the defective or operative status at the point of installation, and will accept no liability beyond the repair or replacement of the product at our factory or authorized service depot.

Head Office:

MIRCOM Technologies Ltd.
8111 Jane Street, Unit #1
Vaughan, Ontario Canada
L4K 4L7
Phone: (905) 660-4655
Fax: (905) 660-4113

U.S.A. Distribution Centre:

MIRCOM Technologies Inc.
4600 Witmer Industrial Estates, Unit#12
Niagara Falls, New York U.S.A.
14305
Phone: (800) 465-5786
Fax: (905) 660-4113